



2018

Catalogo Generale
Products Catalogue

Indice

Table of contents

- 4 La nostra impresa / *Our brand*
- 6 Aspiratori professionali Wet and Dry/ *Professional vacuum cleaners*
- 7 Aspiratori industriali Wet and Dry / *Industrial Wet and Dry vacuum cleaners*
- 8 Aspiratore industriale W 2 / *Industrial vacuum cleaner W 2*
- 9 Aspiratore industriale W 3 / *Industrial vacuum cleaner W 3*
- 10 Aspiratore industriale W 3 Eco / *Industrial vacuum cleaner W 3 Eco*
- 11 Aspiratori trifase Serie M / *Three-phase industrial vacuum cleaner "M"*
- 12 Benne aspiranti brevettate / *Patented vacuuming separators*
- 13 Benne aspiranti customizzabili, 7,5-25 kW /
Custom vacuuming separators, 7,5-25 kW
- 14 Gamma Oil e trucioli / *Oil and metal chips range*
- 16 Foto illustrativa / *Application picture*
- 17 Centrali aspiranti / *Central vacuum units*
- 18 Aspiratori industriali a silos / *Silos vacuum units*
- 19 Depolveratori industriali / *Industrial dust extractors*
- 20 Aspiratori certificati ATEX e fissi a bordo macchina / *ATEX certified vacuum cleaners and fix units on production machinery* 
- 21 Aspiratori ad aria compressa e trasporto pneumatico /
Air operated industrial vacuums and pneumatic transport
- 22 Accessori / *Accessories*
- 23 Appunti / *Notes*





Soluzioni su misura, dal 1964

Tailor made vacuums, since 1964

Dal 1964, DU-PUY costruisce aspiratori industriali per liquidi e solidi destinati a tutte le applicazioni industriali. Fin dal primo aspiratore, la filosofia costruttiva non è stata ispirata alla produzione in serie, bensì alla ricerca di una soluzione artigianale, progettata sulle esigenze del cliente. Questa ispirazione accompagna tutto il team DU-PUY ancora oggi. Dalle fasi di progettazione alla produzione, fino al test sul campo, l'aspiratore viene curato nei minimi dettagli, al fine di garantire la migliore soluzione possibile all'utilizzatore finale.

La gamma oggi è composta da aspiratori monofase e trifase per polveri e liquidi, benne aspiranti brevettate, piccoli e grandi silos aspiranti, sistemi di aspirazione con filtri autopulenti, aspiratori in acciaio inox, aspiratori certificati ATEX e trasportatori pneumatici in depressione.

Scegliere una macchina su misura DU-PUY è la garanzia di optare per la soluzione più efficiente possibile e un accompagnamento dedicato ed affidabile.

From 1964, DU-PUY has been building strong vacuum cleaners for liquids and solids intended for all industrial applications. Since the first unit the company's philosophy was not inspired at massive production. On the contrary, it was always inspired by the search for the perfect solution, uniquely designed to exceed the customer's expectations. This inspiration still leads our whole team today. From the design to the production stages, the machine is customized in every detail, in order to ensure the best solution to the end user.

The range now consists of single-phase and three-phase vacuum cleaners for dust and liquids, patented vacuuming tilting separators, compact and big silos, self-cleaning filters, stainless steel vacuum cleaners, ATEX certified vacuum cleaners and pneumatic conveyors.

Choosing a DU-PUY tailor-made machine is the guarantee to opt for the most efficient solution possible and a dedicated and reliable assistance.



**UN ASPIRATORE PER OGNI SETTORE
A VACUUM CLEANER FOR EVERY ENVIRONMENT**



Aspiratori professionali Wet & Dry

Professional Wet and Dry vacuum cleaners

Aspiratori professionali, compatti e potenti, equipaggiati con motori industriali e robuste plastiche in ABS termoformato. Queste macchine sono ideali per i professionisti del pulito.

Compact and powerful professional vacuum cleaners, featured with industrial motors and sturdy plastics. These machines are ideal for cleaning professionals.



W 800

W 1000

W 1200

W 1500



W 1500C



W 1500 - 1500C : possibilità di insaccamento diretto delle polveri
Possibility to use trash bags



Costruzione robusta
Sturdy construction



Kit accessori d.40 incluso
Accessory kit included



Filtro in poliestere lavabile
Washable polyester filter

Motori / Motors		W 800	W 1000	W 1200	W 1500	W 1500 C
Tensione / Voltage	Volt	230	230	230	230	230
Potenza/Power	W	1000	1000	1000	1000	1000
Depressione/ Depression	mm.H2O	2400	2400	2400	2400	2400
Portata d'aria / Airflow	M3/h	200	200	200	200	200
Superficie filtrante / filter surface	Cm2	1000	2000	2000	2000	2000
Tipo di filtro Ø / filter type Ø	-	Bag / Sacco Ø300	Bag / Sacco Ø300	Bag / Sacco Ø400	Bag / Sacco Ø400	Bag / Sacco Ø400
Efficacia del filtro / filter efficiency	CAT (BIA)	L	L	L	L	L
Capacità/Capacity	Lt	15	25	40	80	80
Bocchettone Ø / suction inlet Ø	mm	32	40	40	40	40
Dimensioni / Dimensions	cm	42x42x62H	42x42x73H	53x53x77H	53x53x89H	53x53x89H

Aspiratori industriali Wet & Dry

Industrial Wet & Dry Vacuum Cleaners

Aspiratori per uso industriale caratterizzati da una solida costruzione e da un'estrema facilità di utilizzo. Possono aspirare qualsiasi tipo di detrito liquido, solido o polveroso. Sono particolarmente indicati per la pulizia di ambienti di lavoro.

Industrial vacuums are characterized by a solid construction and an extreme ease of use. They can vacuum any type of debris liquid, solid or dusty. They are particularly suitable for the cleaning of work environments.



Semplice e rapido svuotamento del contenitore
Costruzione industriale al 100% in acciaio
Contenitore in acciaio INOX di serie



Fast and easy emptying of the container
100% steel construction
Stainless steel container as standard



W 3000



W 4500



W 6000



Contenitore
basculante
Tilting container

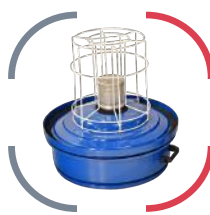

Galleggiante in
alluminio
Integrated floating
device



Kit accessori d.50
incluso
Accessory kit d.50
included

Motori / Motors		W 3000	W 4500	W 6000
Tensione / Voltage	Volt	230	230	230
Potenza/Power	W	2x1000	3x1000	4x1000
Depressione/ Depression	mm.H ₂ O	2400	2400	2400
Portata d'aria / Airflow	M ³ /h	400	600	800
Superficie filtrante / filter surface	Cm ²	5000	7000	9000
Tipo di filtro Ø / filter type	-	Bag / Sacco Ø400	Bag / Sacco Ø460	Bag / Sacco Ø600
Efficacia del filtro / filter efficiency	CAT (BIA)	L	L	L
Capacità/Capacity	Lt	60	100	200
Boccheton Ø/ suction inlet Ø	mm	50	80	80
Dimensioni / Dimensions	cm	72x56x94H	76x76x108H	87x82x126H

Aspiratore industriale W 2

Industrial Vacuum Cleaner W 2

Il W 2 è la grande novità dell'anno 2018 ! Questo aspiratore è ideale per la pulizia e la movimentazione di piccole e medie quantità di materiale, in particolare nei settori dell'industria chimico-farmaceutica, dell'alimentare o nell'industria molitoria. Flessibile, robusto, potente e compatto, le sue prestazioni e la sua manovrabilità ne fanno un prezioso alleato per una pulizia efficace.



Robustezza, potenza e alta capacità di contenimento in solo 1,15 metri di altezza
Superficie filtrante elevata
Compatezza e affidabilità

The W 2 is our main 2018 new product ! This vacuum cleaner is ideal for cleaning and handling small and medium quantities of materials, particularly in the chemical-pharmaceutical, food and milling industries. Easy of use, sturdy, powerful and compact, its performance and manageability make it a valuable ally for effective cleaning.



1,15 meters of robustness, power and great containment capacity
High filtration surface
Compactness and reliability



Contenitore a sgancio
Detachable bin



Gancio appendicavo
Cable hook



Filtro a tasche di grande superficie
Certified and large L Class surface pocket filter



Kit accessori d.40 incluso
D.40 accessory kit included

Tensione / Voltage	Volt	230
Potenza / Power	W	2x1000
Depressione max. / Water lift max	mm.H ₂ O	2400
Portata d'aria max. / Air flow max.	M ³ /h	400
Superficie filtrante / Filter surface	Cm ²	20000
Tipo di filtro Ø / Filter type Ø		Star /Tasche - Ø 420
Efficienza filtro / Filter efficiency	CAT (BIA)	L
Capacità contenitore / Tank capacity	Lt.	40
Bocchettone Ø / Suction inlet Ø	mm.	50
Dimensioni / Dimensions	cm.	55x62x115H

Aspiratore industriale W 3

Industrial Vacuum Cleaner W 3

Il W 3 si distingue da subito per le sue caratteristiche di funzionalità, design e robustezza. Il W 3 combina la forza di tre motori monofase tradizionali per ottenere risultati straordinari. Il design funzionale del W 3 è il risultato di più di 50 anni di esperienza a contatto diretto con gli utilizzatori. Può aspirare qualsiasi tipo di detrito liquido, solido o polveroso, anche simultaneamente. E dotato di un contenitore a sgancio rapido, con possibilità di insaccamento.



Semplice e rapido svuotamento del contenitore
Costruzione industriale al 100% in acciaio
Costruzione in acciaio INOX su richiesta

W 3 stands out immediately for its functionality, design and its sturdiness. W3 combines the elements of a traditional single-phase vacuum cleaner in an innovative way in order to achieve extraordinary results. The functional design of the W 3 is based on over 50 years of experience in direct contact with users. W 3 can vacuum any kind of debris, like liquid, solid or powder. It proposes a tilting container with an easy emptying system and the possibility to use disposable bags.



Easy and fast emptying of the container
100% industrial steel construction
Stainless steel construction on request



W 3



Contenitore a sgancio
Detachable bin



Porta accessori metallico integrato
Iron basket for accessories



Filtro a tasche di grande superficie
Large surface class L certified pocket filter



Kit accessori d.50 incluso
D.50 accessory kit included

Tensione / Voltage	Volt	230
Potenza / Power	W	3x1000
Depressione max. / Water lift max	mm.H2O	2400
Portata d'aria max. / Air flow max.	M3/h	600
Superficie filtrante / Filter surface	Cm2	20000
Tipo di filtro Ø / Filter type Ø		Star /Tasche - Ø 460
Efficienza filtro / Filter efficiency	CAT (BIA)	L
Capacità contenitore / Tank capacity	Lt.	60
Bocchettone Ø / Suction inlet Ø	mm.	80
Dimensioni / Dimensions	cm.	58x60x135H

Aspiratore industriale W 3 Eco

Industrial Vacuum Cleaner W 3 Eco



W 3 Eco



L'aspiratore industriale W 3 è anche disponibile in versione trifase, chiamata W 3 Eco, per effettuare lavori continuativi. Il W 3 Eco può aspirare senza fermarsi mai qualsiasi tipo di detrito liquido, solido o polveroso, anche simultaneamente. E dotato di un contenitore a sgancio rapido, con possibilità di insaccamento.



Semplice e rapido svuotamento del contenitore
Innovativo chassis per la massima robustezza

The W 3 is also available in three-phase version, called W 3 Eco, for continuous work. The W 3 Eco can vacuum any kind of debris, like liquid, solid or powdery. It features a tilting container with an easy emptying system and the possibility to use a plastic bag.



Easy and fast emptying of the container
Innovative 100% welded chassis for maximum sturdiness
Easy access to the filter for quick maintenance



Quadro elettrico ABB a comando rotativo / Silenziatore sullo scarico per garantire la più alta silenziosità del mercato !

ABB electrical panel with an innovative rotative control / Silencers integrated to achieve the lowest noise level in the market!



Macchina disponibile in 2,2 Kw o 4 Kw
Available in 2,2 Kw or 4 Kw



Kit accessori d.50 incluso
D.50 accessory kit included

Modelli / Models		W 3 Eco 2.2 kW	W 3 Eco 4kW
Tensione / Voltage	Volt	400	400
Potenza / Power	kW	2,2	4
Depressione max. / Water lift max	mm.H ₂ O	3000	3200
Portata d'aria max. / Air flow max.	M ³ /h	320	450
Superficie filtrante / Filter surface	Cm ²	20.000	20.000
Tipo di filtro Ø / Filter type Ø		Star /Tasche - Ø 460	Star /Tasche - Ø 460
Efficienza filtro / Filter efficiency	CAT (BIA)	L	L
Capacità contenitore / Tank capacity	Lt.	60	60
Bocchettone Ø / Suction inlet Ø	mm.	80	80
Dimensioni / Dimensions	cm.	58x60x155H	58x60x155H

Aspiratori industriali Trifase Serie M

Three-phase vacuum cleaners

Gli aspiratori industriali trifase DU-PUY sono macchine prestanti, ideali per applicazioni in continuo. Con potenze comprese tra 4 e 7,5 kW, il contenitore estraibile e la indistruttibile costruzione in acciaio, queste macchine non hanno bisogno di manutenzione e sono un vero e proprio investimento di lungo termine per le aziende di qualsiasi settore industriale.

DUPUY's three-phase industrial vacuum cleaners are true performance machines, ideal for continuous duty applications. With a power range of 4 to 7.5 kW, the removable container and the indestructible steel construction, these vacuum cleaners are a long-term investment for companies of any industrial sector.



M 50



Quadro elettrico integrato e cassetto porta accessori
Integrated electric panel and accessory drawer

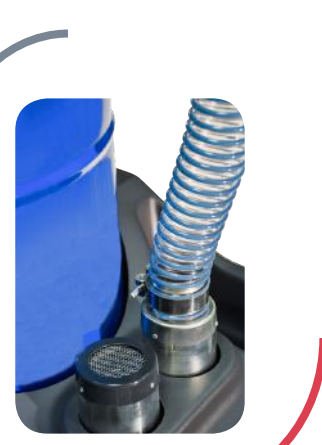

Massima silenziosità
Extremely silent



Motori / Motors		M 50	M 50 Serie	M 70	M 90
Tensione / Voltage	Volt	400	400	400	400
Potenza/Power	kW	4	4,3	5,5	7,5
Depressione/ Depression	mm.H2O	3200	5100	3000	4000
Portata d'aria / Airflow	M3/h	450	320	530	530
Superficie filtrante / filter surface	Cm2	20.000	20.000	20.000	20.000
Tipo di filtro Ø / filter type Ø /	-	Tasche / Star- Ø460	Tasche / Star- Ø460	Tasche / Star- Ø460	Tasche / Star- Ø 460
Efficacia del filtro / filter efficiency	CAT (BIA)	L	L	L	L
Capacità / Capacity	Lt	100	100	100	100
Bocchetone Ø/ suction inlet Ø	mm	80	80	80	80
Dimensioni / Dimensions	cm	125x65x155H	125x65x155H	125x65x155H	125x65x155H

Benne aspiranti brevettate per il recupero di grandi quantità di materiali liquidi e solidi

Patented vacuuming separator for big quantities of materials

Le benne aspiranti DU-PUY sono indistruttibili aspiratori industriali, con capacità di raccolta comprese tra i 150 e i 400 lt. Grazie ad una costruzione modulare, possono essere equipaggiati sia con motori monofase che trifase per il lavoro in continuo. La caratteristica principale di questi modelli è la loro solidità, garantita da una costruzione con lamiera di 4 mm di spessore.

DU-PUY's vacuuming separators are sturdy industrial vacuum cleaners with collection capacity up to 400 lt. Thanks to their modular construction they can be equipped with either single-phase and three-phase motors. Their true unique feature is the toughness of the construction, which is guaranteed by a 4 mm thick steel layer.



B 4000



B 4500



B 6000



I dettagli che fanno la differenza:

- Potenti motori monofase by-pass (3 o 4) o turbine trifase per lavoro in continuo esenti da manutenzione
- Predisposizione per trasporto e scarico rapido con muletto

The details making the difference:

- Powerful single-phase by-pass motors (3 or 4) or three-phase turbines for a continuous and maintenance-free work.
- Perfect for transport and rapid unloading with forklifts



Modelli / Models		B 4000	B 4500	B 6000
Tensione / Voltage	Volt	230	230	230
Potenza/Power	W	3x1000	3x1000	4x1000
Depressione/ Depression	mm.H2O	2400	2400	2400
Portata d'aria / Airflow	M3/h	600	600	800
Superficie filtrante / filter surface	Cm2	14.000	14.000	30.000
Tipo di filtro Ø / filter type Ø /	-	Tasche / Star- Ø 460	Tasche / Star- Ø 460	Tasche / Star Ø 600
Efficacia del filtro / filter efficiency	CAT (BIA)	L	L	L
Cap. liquidi/ Liquids cap.	Lt	150	150	200
Cap. solidi/ Solids cap.	Lt	150	150	200
Bocchetone / suction inlet	mm	90	90	90
Dimensioni / Dimensions	cm	93x81x124H	3x81x124H	110x94x150H
Sistema. di scarica / discharge system		Ribaltamento / Tilting 45°	Ribaltamento / Tilting 90°	Ribaltamento / Tilting 45°



Griglia di separazione olio-trucioli in acciaio zincato
Oil and metal chips separator, galvanized steel made

Soluzioni personalizzate, da 7,5 a 25 kW

Customized solutions, from 7,5 up to 25 kW

Per le applicazioni più pesanti, DU-PUY ha creato delle benne aspiranti in versione trifase, con potenze che vanno dai 7 kW ai 25 kW. Queste unità modulari garantiscono molti vantaggi, tra i quali facilità di scarico, costruzione robusta e durevole e assenza di bisogno di manutenzione ordinaria grazie al un motore dalla vita potenzialmente infinita.

The suction bucket model is also available in three-phase version, with capacities ranging from 5.5 to 25 kW, for heavier applications. These modular units offer many advantages: easy unloading, highly industrial construction, exemption of ordinary maintenance.



B 60



Grande potenza di aspirazione e capacità di raccolta
Great suction power and capacity



Predisposizione per inforcamento a muletto, massima manovrabilità e facilità di scarico
Forklift ready, max maneuverability and ease of discharge



Modelli / Models		B 40	B 60	B 80
Tensione / Voltage	Volt	400	400	400
Potenza/Power	kW	7,5	12,5	25
Depressione/ Depression	mm.H2O	4000	4400	4500
Portata d'aria / Airflow	M3/h	700	1100	2100
Superficie filtrante / filter surface	Cm2	14.000	30.000	70.000
Tipo di filtro Ø / filter type Ø /	-	Tasche / Star Ø 460	Tasche / Star Ø 600	Tasche / Star Ø 600
Efficacia del filtro / filter efficiency	CAT (BIA)	L	L	L
Cap. liquidi / Liquids.Cap	Lt	150	200	200
Cap. solidi / Solids. Cap	Lt	150	200	200
Dimensioni / Dimensions	cm	160x75x160H	160x87x160H	180x95x170H
Sistema. di scarica / discharge system		Ribaltimento Tilting /90°	Ribaltimento Tilting /45°	Ribaltimento Tilting /45°

Aspiratori per **separazione** olio e trucioli monofase e trifase

Gli aspiratori della Linea OIL sono macchine studiate appositamente per l'industria e le officine meccaniche. Permettono di effettuare in maniera rapida ed efficiente la pulizia e la manutenzione di CNC, torni automatici e macchinari in generale. Grazie al loro design, è possibile recuperare e filtrare allo stesso tempo grandi quantità di liquidi e trucioli metallici anche pesanti. Questo sistema consente all'utilizzatore di riutilizzare l'olio o il lubrificante refrigerante riciclato per un massimo risparmio.

The OIL series sump cleaners are machines designed for the heavy duty maintenance of mechanical, engineering and automotive industries. These machines allow you to quickly and efficiently perform the cleaning and maintenance of CNC machines. Thanks to their design, you can retrieve and filter, at the same time, large quantities of liquids and metal chips.

The collected lubricating oil can then be reused several times and make you save time and money.



B 3000 OIL



B 5000 OIL



W 1500 OIL



Cestello estraibile in acciaio forato per la ritenzione di trucioli metallici
Valvola di scarico dei liquidi



Galvanized steel sieve grid for the retention of metal chips and swarf
Easy Oil discharge system

Modelli / Models		W 1500 OIL	B 3000 OIL	B 5000 OIL
Tensione / Voltage	Volt	230	230	230
Potenza/Power	W	1000	3x1000	3x1000
Depressione/ Depression	mm.H2O	2400	2400	2400
Portata d'aria / Airflow	M3/h	200	600	600
Superficie filtrante / filter surface	Cm2	2000	14.000	14.000
Tipo di filtro Ø / filter type Ø /	-	Sacco / Bag polypropilene Ø400	Tasche idro-oleofobico / Star oleophobic Ø 460	Tasche idro-oleofobico / Star oleophobic Ø 460
Efficacia del filtro / filter efficiency	CAT (BIA)	-	M	M
Cap. liquidi / Liquids. Cap	Lt	65	150	250
Cap. solidi / Solids Cap.	Lt	10	40	100
Dimensioni / Dimensions	cm	93x53x89H	120x60x130H	95x80x125H
Sistema. di scarica / discharge system	-	Valvola a sfera manuale / Ball valve	Pompa elet. / Elec. pump 300 Lt included	Pompa elet. / Elec. pump 300 Lt included

Single phase and three-phase vacuum cleaners for oil and metal chips



Cestello in acciaio forato per la ritenzione dei trucioli metallici

Stainless steel sieve grid for the retention of metal chips and swarf



Valvola di scarico manuale e pompa di scarico indipendente con portata di 300lt/min

Manual discharge valve and independent discharge pump with 300lt/min flow



B 50 Eco Oil



B 90 Oil

Modelli / Models		B 50 Eco OIL	B 70 OIL	B 90 OIL
Tensione / Voltage	Volt	230	400	400
Potenza/Power	kW	4	7,5	12,5
Depressione/ Depression	mm.H2O	3600	4000	4400
Portata d'aria / Airflow	M3/h	350	530	1100
Superficie filtrante / filter surface	Cm2	14000	14.000	14.000
Tipo di filtro Ø / filter type Ø /	-	Tasche idro-oleofobico / Star oleophobic Ø 460	Tasche idro-oleofobico / Star oleophobic Ø 460	Tasche idro-oleofobico / Star oleophobic Ø 460
Efficacia del filtro / filter efficiency	CAT (BIA)	M	M	M
Cap. liquidi / Liquids Cap.	Lt	250	400	400
Cap. solidi / Solids Cap.	Lt	100	120	120
Dimensioni / Dimensions	cm	95x80x125H	140x75x160H	180x95x160H
Sistema. di scarico / discharge system		Pompa elet. 300 lt Elec. pump 300 lt included	Pompa elet. 300 lt Elec. pump 300 Lt included	Pompa elet. 300 lt Elec. pump 300 lt included



PASSIONE, INNOVAZIONE, PRECISION
PASSION, INNOVATION, PRECISION

**DUPUY**
TAILOR MADE VACUUMS

Centrali aspiranti con **filtrazione automatica**

Central vacuum units with automatic filtration

Le centrali aspiranti con sistema di pulizia del filtro automatico DU-PUY sono ideali per la realizzazioni di impianti centralizzati di aspirazione.

Un impianto di aspirazione centralizzato è la miglior soluzione per la pulizia e la manutenzione di grandi aree di lavoro come fonderie, acciaierie e ovunque vi siano grandi quantità di materiali da recuperare. Ogni impianto viene processato sulle esigenze del cliente. Si integra perfettamente negli ambienti di lavoro nei quali verrà usato.

DU-PUY's central vacuums with automatic filter cleaning system are ideal for the realization of centralized vacuum systems.

A centralized vacuum cleaning system is the perfect solution for cleaning and maintenance of large work areas such as foundries, steel mills, and wherever there are large amounts of material to be recovered. Each plant is designed specifically to meet the customer's requirements, making it perfectly integrated in the work environments for which it has been designed.



CVAC 40



 Turbine trifase con potenze da 5,5kW a 25 kW
Sistema pneumatico automatico di pulizia dei filtri
Contenitore da 220 Lt con ribaltamento frenato tramite cilindro.

 *Three-phase side channel blowers with a power range of 5,5kW up to 25 kW*
Automatic pneumatic filter cleaning system
220 Lt tilting container with automatic braking safety system

Modello/ Model	Motore/ Motor	Potenza / Power	Depressione / Water lift	Portata d'aria / Airflow	Filtro / filter	Superficie filtrante / filter surface	Capacità/ Capacity	Bocchettone / Suction Inlet Ø	Dimensioni / dimensions
CVAC 40	400 V	7,5 kW	4000 mmH2O	700 m3/h	Cartucce Cartridge	20 cm2	250 lt	90 mm	170x105x203H
CVAC 60	400 V	12,5 kW	4400 mmH2O	1100 m3/h	Cartucce Cartridge	20 cm2	250 lt	90 mm	170x105x203H
CVAC 80	400 V	25 kW	4500 mmH2O	2200 m3/h	Cartucce Cartridge	20 cm2	250 lt	120 mm	170x105x203H

Aspiratori industriali a Silos

Silos vacuum units

Gli aspiratori industriali a SILOS DU-PUY sono tra le macchine più versatili della gamma. Possono essere realizzati in versione mono o trifase, con struttura cilindrica o cubica, in acciaio verniciato o inox, con scarico a paletta, a farfalla, a ghigliottina o molte altre tipologie ancora.

Grazie alle numerose possibilità di configurazione, gli aspiratori a Silos possono essere utilizzati con efficacia in ogni ambito industriale.

DU-PUY's SILO vacuum units are among the most versatile machines in the range. Available in single- or three-phase version, with cylindrical or cubic structure, in painted or stainless steel, with a wide variety of discharge systems to choose from.

Thanks to the thousands of design options, they can be used effectively in any kind of industrial environment.

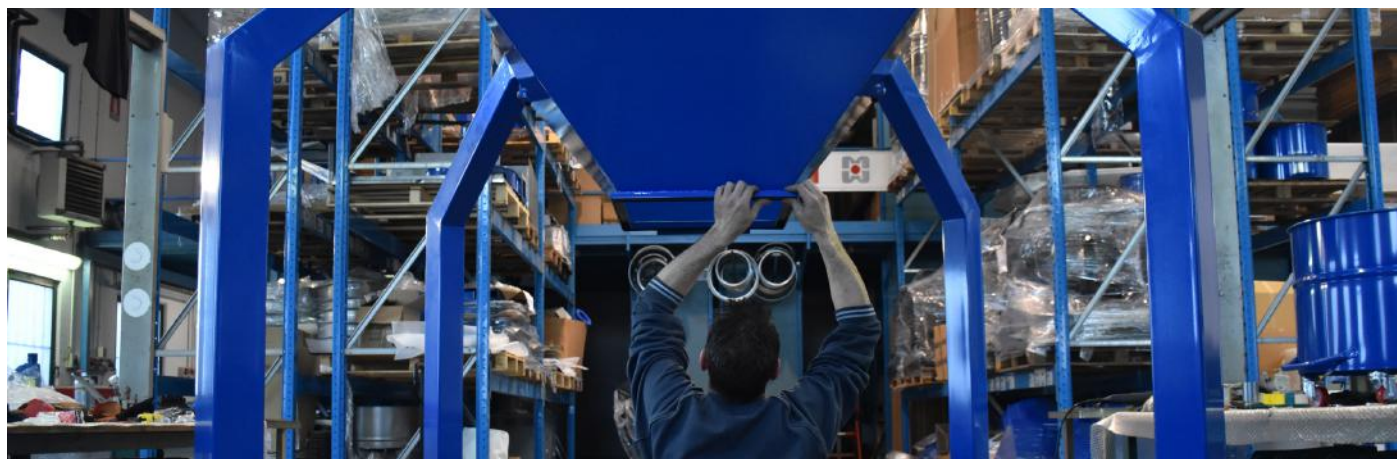

Motori mono o trifase con potenze fino a 25kW
Capacità di raccolta da 100 lt fino a 1 m3
Molteplici possibilità di scarico: valvola a farfalla, sacco big-bag, porta basculante, ghigliottina, ecc.



Single or three phase motors with power up to 25kW
Collection capacity from 100 lt to 1m3
Multiple discharge systems: butterfly valve, big-bag, tilting trapdoor, guillotine, etc.

L'unico aspiratore cucito sulle tue esigenze
The only vacuum cleaner, truly made on your needs



S 6004



S 6002



S 602



S 605 ATEX

Depolveratori industriali

Industrial dust extractors

I depolveratori industriali DU-PUY sono aspiratori a bassa pressione ideati per il recupero di polveri in sospensione nell'aria. Le unità aspiranti vengono abbinate ad un impianto studiato sui bisogni del cliente. Questo può comprendere punti di aspirazione fissi o mobili, anche a bordo macchina.

Queste unità sono idonee per tutte le industrie ove vi sia movimentazione di polveri, come nei settori alimentare o meccanico per il recupero di polveri di molatura.

The DU-PUY industrial dust collectors are low pressure vacuum units, designed for recovery of airborne dust. These suction units are engineered to work with a fixed installation, which is designed on the needs of the customer. This may include fixed or mobile suction points or arms, including direct extraction applications on third party machines. These units are ideal for every industry where dust and powders are processed, like food industry or metal working workshops.



Filtri a cartuccia di grandi dimensioni
Sistema pneumatico automatico di pulizia dei filtri



High cartridge filtration surface
Automatic filter cleaning system



Dedust 50



Customized Dedust 50

Modelli / Models		Dedust 30	Dedust 50
Tensione / Voltage	Volt	400	400
Potenza/Power	kW	2,2	4
Depressione/ Depression	mm.H2O	280	350
Portata d'aria / Airflow	M3/h	1300	2700
Superficie filtrante / filter surface	Cm2	120.000	400.000
Tipo di filtro Ø / filter type Ø /	-	4 cartucce 4 cartridges	4 cartucce 4 cartridges
Efficacia del filtro / filter efficiency	CAT (BIA)	ANT M	ANT M
Capacità/Capacity	Lt	50	130
Bocchetone / suction inlet	mm	150	200
Dimensioni / Dimensions	cm	60x60x220H	120x120x320H



Dedust 30

Aspiratori certificati ATEX

Atex certified vacuum cleaners



DU-PUY costruisce e certifica una ampia gamma di aspiratori ATEX, idonei per l'utilizzo in zone a rischio di esplosione. Gli aspiratori DU-PUY sono dotati di molteplici sistemi di sicurezza atti a prevenire l'insorgere di esplosioni come: messa a terra, filtri antistatici, motori certificati.

DU-PUY builds and certifies a wide range of ATEX vacuum cleaners, suitable for use in hazardous areas. DU-PUY's vacuum cleaners are equipped with multiple safety systems to prevent the triggering of explosions as: electrical grounding, antistatic filters, certified motors.

I nostri aspiratori sono certificati Zona 22 e Zona 21.

We provide vacuum cleaners certified for Zone 22 and Zone 21



W3 Eco ATEX

M50 ATEX Zone



Dove sono necessari gli aspiratori ATEX ?

La presenza degli aspiratori certificati ATEX è spesso obbligatoria per legge in ambienti quali: industria molitoria, alimentare, lavorazione dei cereali, lavorazione dell'alluminio, polveri esplosive o infiammabili, industria del legno, industria chimico-farmaceutica.

Where are these ATEX vacuum cleaners needed?

ATEX certified vacuums are often required by law in environments such as flour mills, cereal processing, food industries, aluminum processing factories, in presence of explosive or flammable dust is involved, the wood industry, the chemical and pharmaceutical industry.

Aspirazione fissa a bordo macchina

Fixed unit on production machinery

Le unità fisse d'aspirazione a bordo macchina vengono utilizzate maggiormente durante il processo di estrazione di sfridi e polveri. La loro configurazione modulare consente loro di integrarsi perfettamente e discretamente sulle linee di produzione o sulle macchine.

The fixed suction units allow you to extract directly the scraps and dust on your assembly lines. Their modular configuration make them adaptable to any productive environment.



TS 70



SK 10



Aspiratori ad **aria compressa** *Air operated Industrial Vacuums*

DU-PUY produce aspiratori ad aria compressa per aspirare polveri, liquidi e solidi. Queste macchine sono adatte agli ambienti nei quali una fonte d'energia elettrica è inesistente o considerata come pericolosa.

DU-PUY manufactures Air operated vacuums to suck up powders, liquids and solids. These machines are suitable for environments where an electric power source is non-existent or considered as dangerous.



W 3 AIR



B 4500

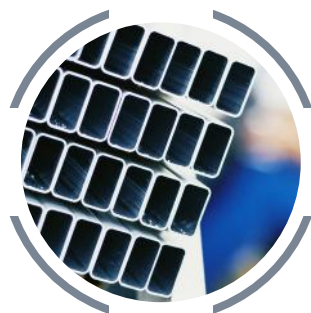

Trasporto **pneumatico** *Pneumatic conveyor*

La tecnologia sviluppata da DU-PUY per il trasporto pneumatico delle polveri e granuli consente la movimentazione di materiali sfusi in polvere o granuli all'interno di una tubazione. Il percorso può coprire elevate distanze e differenti portate (kg/h di prodotto aspirato e scaricato nel punto di utilizzo).

Queste macchine sono adatte per il trasporto di materiali in granuli o polverosi come PVC, caffè, cacao, cereali, ecc.

The technology developed by DU-PUY for the pneumatic transport of dust and grains allows to carry bulk material inside a pipeline for long distances and different air flow rates (kg/h) of vacuumed and discharged product at point of use. These machines are suitable for transportation of grains or dust such as PVC, coffee, cocoa, cereals...

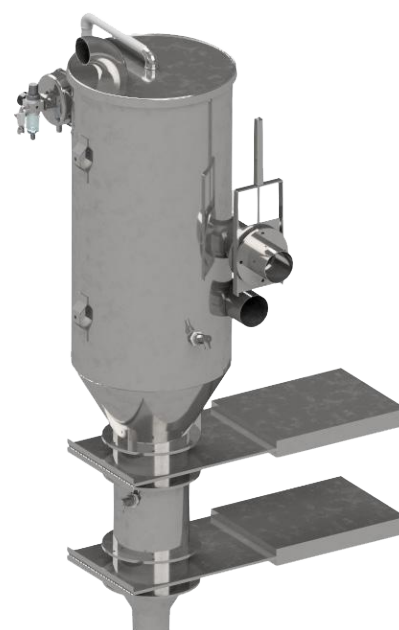

Accessori / Accessories

Wet and Dry D.40 / *Wet and Dry D.40*



ATEX Wet and Dry D.50 / *ATEX and WD Kit D.50*



Olio e trucioli / *Oil and metal chips*



Meccanica / *Engineering*



Manutenzione dei forni / *Oven cleaning*



Dry D.70 / *Accessory Kit Dry D.70*



Componenti per impianti centrali *Centralized vacuum system accessories*

DU-PUY fornisce tutta la componentistica necessaria per la realizzazione di un impianto di aspirazione centralizzato.

DU-PUY provides you all the necessary components for the realization of a centralized vacuum system.

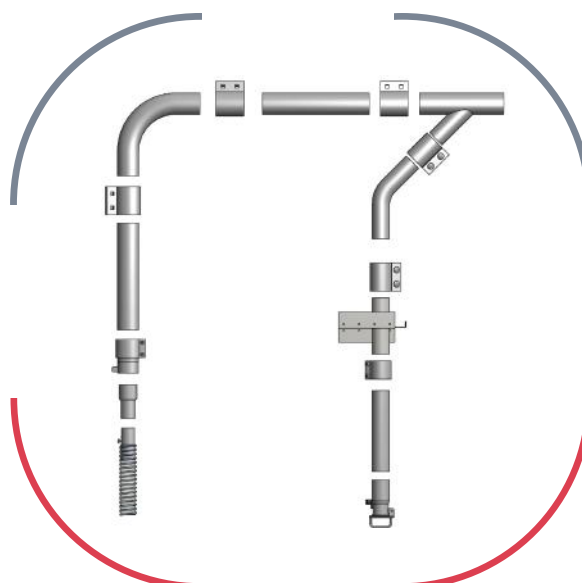

Appunti / Notes





DU-PUY Srl

Via Sacro Monte 3/8 - 21052 Busto Arsizio (VA)

Tel. +39 0331682812

Fax +39 0331682814

info@dupuy.it

www.dupuyvacuums.com